



STAND-ALONE SYSTEM EVOWELD

Universal solution for laser plastic welding

AUTOMOTIVE | MEDTECH | CONSUMER

► Universal laser welding unit

Highest economic efficiency

Low space requirement

Reliable processing

Manual or automatic loading

Intuitive EvoLaP process software

Evosys Calibrated Quality Concept

EvoWeld

THE UNIVERSAL SOLUTION FOR LASER WELDING OF PLASTIC

The EvoWeld is a universal laser welding machine for processing small and medium series. Depending on the application, the system can be equipped with different laser sources and optics modules, thus offering a wide area of operations. With a footprint of approx. 1 m², it fits into any application environment.

Virtually maintenance-free and service-friendly, the EvoWeld is predestined for use in 24/7 production. Manual loading or integration into fully automated production lines - the machine is ideally suited for both, as a corresponding interface for communication with a handling system or customer-specific feed equipment is already on board as standard. The cycle time-optimized controls ensures maximum output even for high-volume applications with very short operating cycles.

The intuitive EvoLaP process software makes the machine easy to operate and allows the user to implement a wide variety of processing tasks. The EvoWeld goes through Evosys Laser GmbH's unique CQC calibration concept, which ensures comparability of systems. To guarantee quality even during production at the customer's site, the system is also available with various online monitoring modules.



**Laser-welded parts
from the application areas
Automotive, Medical, Consumer**



Laser power measurement

Force measurement

Mechanical alignment tools



The calibration tools specifically optimized for the EvoWeld enable rapid checking of the essential process parameters with minimum time expenditure. Our EvoLaP process software easily guides the machine setter through the relevant procedure, automatically

documents the results and automatically adjusts the machine's internal parameters if necessary. This ensures constant high weld quality and maximum production stability with minimum time required for system calibration.

Technical specifications

Laser class	1
Laser wavelength	980nm – other wavelengths on request
Laser power	250W – higher power on request
Processing field	Single clamping 180 x 180 mm (1 part)
	Double clamping 90 x 180 mm (2 parts)
Power supply	400 V, 50-60 Hz, max. 3 kW
Air supply	4.5 to 10 bar compressed air according to DIN 8573-1 class 1-4-1
Configuration	Dual rotary table (Servo driven)
	High precision collapse control
	Automatic clamping force control
	Lighted loading/unloading area
	Industrial PC with multi-language HMI, touch optimized
	Open interfaces
	EvoLaP process software
Options	output increase, temperature control, force measuring system,
	package «automatic assembly», tool coding, part recognition, NIO box, transformer
Dimensions (WxDxH)	See layout sketch

The EvoWeld has a standard housing. All components such as laser, control unit and rotary indexing table are integrated in the housing. The system can be used for both contour and quasi-simultaneous processes.

Version 2023-07 / technical data are subject to change.

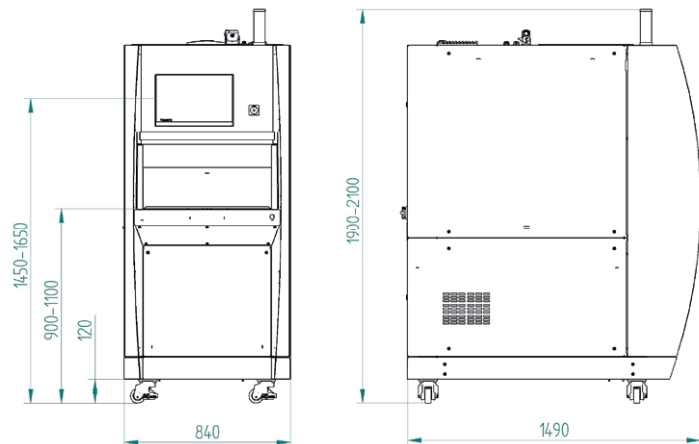

EVOSYS is the ideal partner for laser welding of plastics. Whether a simple off the shelf machine or complex customized systems, we will convert your challenges into solutions. We are the specialists when it comes to bringing the latest optical technology into your production!

**EVOSYS is certified
ISO 9001:2015**

GERMANY

Evosys Laser GmbH
Internet www.evosys-group.com



**DYNAMIC.
INNOVATIVE.
QUALITATIVE.**